

OTR retreading machine OTRetread



Fully automatic buffing, peeling and grooving machine for OTR tires up to 63"

- innovation made by COLLMANN
- high-end solution of well proven COLLMANN buffing machines
- the modular design meets customer requirements for tailor-made version
- quick change rim system with highest positioning precision
- contour controlled buffing and precision grooving
- various features and options – *please contact us for any further informations*

OTR retreading machine OTRetread, technical data

Fully automatic buffing, peeling and grooving machine for OTR tires up to 63"

➤ **Tire dimensions**

- outer diameter 1200-4600 mm
- section width 450-1650 mm
- bead diameter 22-63"
- tire weight max. 6200 kg

➤ **Machine includes**

- 3-axle servo positioned operating head
- quick change rim system
- one set of rim plates
- buffing and peeling station

➤ **Machine options**

- hand controlled buffing
- brushing tool
- grooving unit
- material discharge conveyor
- laser controlled contour measurement and setting

➤ **Machine colours**

COLLMANN standard,
other RAL-colours
on request

➤ **Machine dimensions**

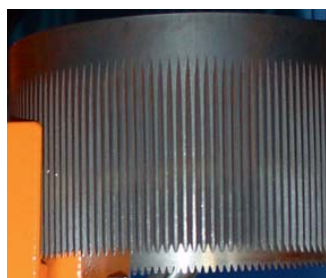
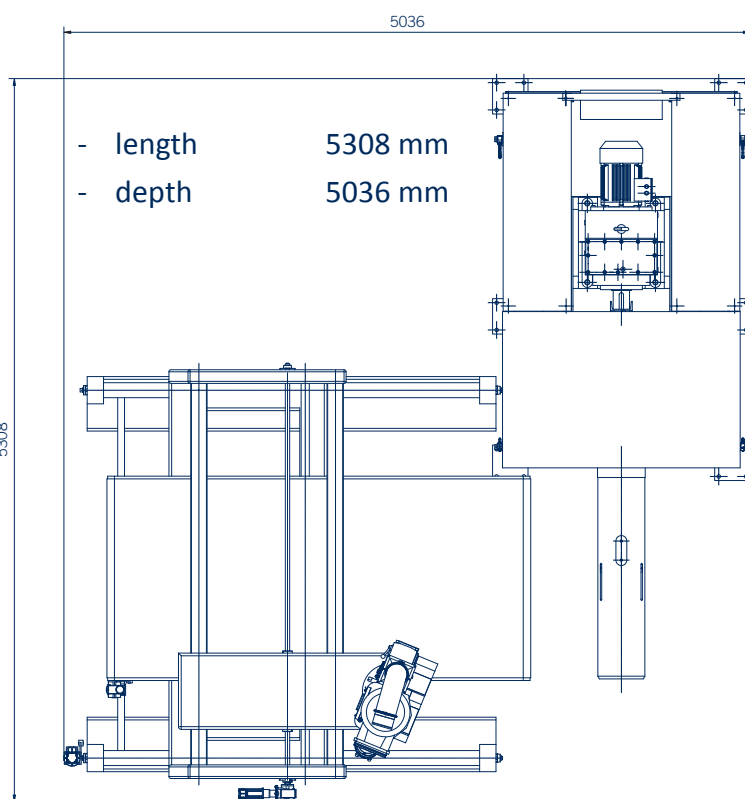

Subject to technical modifications.

COLLMANN Tire Systems & Services GmbH

Moislinger Allee 224, 23558 Lübeck, Germany

Phone: +49-451-890960, Fax: +49-451-8909624, e-mail: contact@collmann.com, www.collmann.com